

Technical Guide

CONTINUOUS UPS IN DATACENTRE

Produced by the UPS Working Group of ANIE Automazione

November 2017



The logo for ANIE AUTOMAZIONE features a stylized blue and grey geometric icon on the left, followed by the word "ANIE" in a bold, blue, italicized sans-serif font, and the word "AUTOMAZIONE" in a bold, grey, sans-serif font below it.

ANIE
AUTOMAZIONE

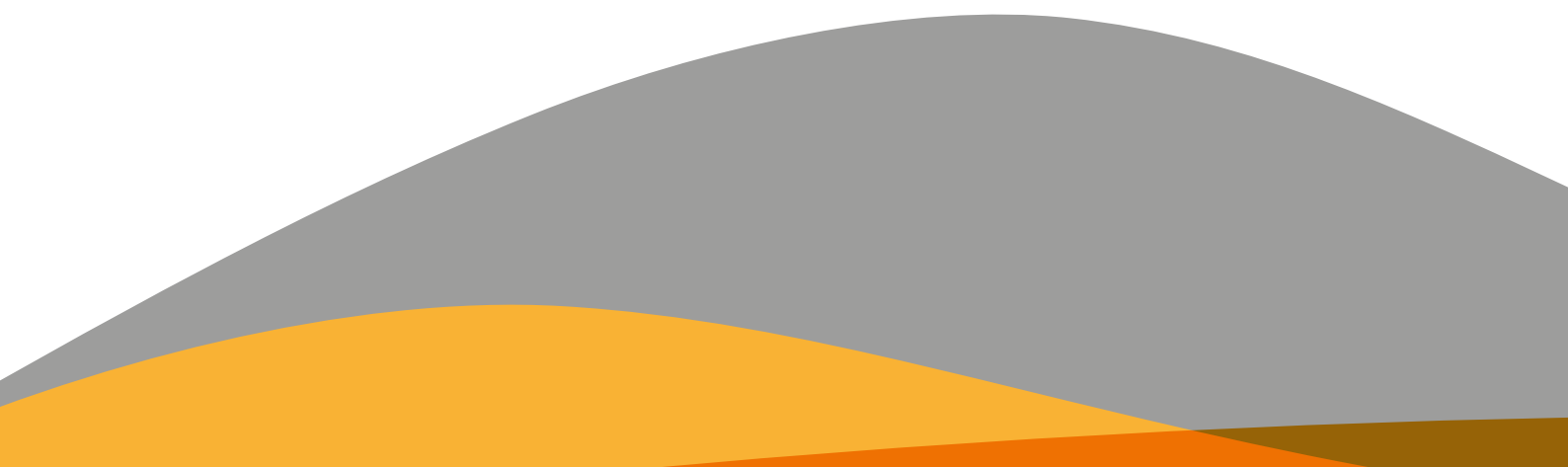

Introduction

Used by a broad variety of different industries, **datacentres are vital to the functioning of a today's systems of production** and the modern economy. When opting for an Uninterruptible Power Supply (UPS), it is vital to choose a type suited to its task, and to ensure that the installation and servicing are done properly.

Yet the scarcity of accurate and reliable technical documentation makes it difficult for system engineers and installers to meet the challenges of selecting, installing and running a system that best fits the customer's needs.

This guide, prepared by the ANIE Automazione working group on UPS systems, is intended to help technicians come up with high-performance solutions with a low environmental impact that meet the demands of their customers.

Technical Guide

CONTINUOUS UPS IN DATACENTRE

Produced by the UPS Working Group of ANIE Automazione

A **datacentre** is either a physical space (such as a room, warehouse or building) or a virtual environment hosting a series of servers and ancillary equipment for the storage, **management and transmission of large volumes of data** and information. Each datacentre is configured according to the type of data used and the characteristics of the organization running it, and should be able to supply the data remotely and on demand in real time. A datacentre will contain servers, data storage devices, electronic systems, a telecommunications infrastructure and related accessory equipment. A datacentre will also contain environmental controls, such as air-conditioning units, fire suppression systems and other security devices.

Regardless of size, every datacentre must be configured so that it can continuously operate at full capacity and maintain constant full availability.

Certain elements of the datacentre may change. If, for example, an increase in the number of internal or external users leads to an increase in the number of services requested, then the processing power of the datacentre will likewise need to be enhanced.

A great deal depends on the availability of space, the location of the datacentre, climate control requirements, the physical infrastructure and the utility provider, as well as on the availability, continuity and cost of electricity.

It is absolutely essential **protect** the datacentre from interruptions and operating inefficiencies to ensure continuity of business activity.

Without sufficient protection of power sources, a datacentre **will sooner or later suffer an interruption**, leading to the loss of information, productivity and profit.

No single electricity supplier can be relied upon to guarantee a continuous uninterrupted power supply to a datacentre. Often the continuity of electricity supply is inadequate, and unless proper safeguards are in place, networking equipment can often be damaged by mains faults. An accidental voltage sag or a blackout can be extremely costly.

To ensure continuous power supply and reduce the vulnerability of a datacentre to problems such as voltage sags or spikes or a complete loss of power, **datacentres rely on Uninterruptible Power Supply (UPS) units**. Generally a UPS unit is located between the mains power and the critical equipment, it assures a high quality and continuous supply of power regardless of the state of the mains supply.



It can continue to supply power for a given amount of time (usually for minutes but sometimes even for hours) when the primary source of power becomes completely unavailable.

Also, by filtering out disturbances and distortions of mains, a UPS unit can ensure that critical equipment will be supplied with a voltage that is reliable and compatible with the tolerance limits of the electronic devices.

A UPS UNIT GENERALLY CONSISTS OF THREE MAIN ELEMENTS:

A rectifier-charger that converts alternating current (AC) into continuous direct current (DC).

Accumulators that store energy and instantaneously supply it to the system in case of mains failures.

A static converter (inverter) to turn direct current into a perfectly stabilized and filtered alternating current at a given voltage and frequency.

A UPS unit can include automatic bypass switch (to deal with inverter faults and overloads) and manual bypass switch (for systems maintenance).

The installation of a UPS in a datacentre requires decisions to be made regarding the size and type of the UPS, its installation and maintenance requirements, and the energy savings it can bring.

1 UPS SIZE EVALUATION

When deciding on the size of the UPS, the following factors need to be taken into consideration:

The critical load power, with references to apparent power and active power.

The nature of the critical load that needs to be supplied.

Whether service loads (e.g. air conditioning) need to be added to the critical load power value.

The typology of service loads (motors, compressors etc.).

The future growth scenario of critical and service loads.

2 UPS TYPOLOGY EVALUATION

The typology of datacentre infrastructure needs to be taken into account.

By way of example, it is possible referring to the guidelines of the Uptime Institute, an organisation that classifies datacentres in four “tier” (I, II, III or IV). Each tier corresponds to a certain availability guarantee depending on type of materials used, redundancy, electrical plant, ect. Tier classification is progressive, with each higher tier offering more guarantees of continuity and resilience than the one below. The higher the tier, however, the higher the installation and maintenance costs.

The following table explains tiers differences.

| | Tier I | Tier II | Tier III | Tier IV |
|---|------------|----------|---------------------------|------------------------|
| Active capacity components to support IT load | N | N+1 | N+1 | N After any failure |
| Distribution paths | 1 | 1 | 1 Active 1 Alternative | 2 Active |
| Concurrently maintainable | No | No | Yes | Yes |
| Fault tolerant | No | No | No | Yes |
| Compartmentalization | No | No | No | Yes |
| Continuous cooling | | | Depends on load | Yes |
| Continuous Duty Generators | | | Yes | Yes |
| Environment temperature | | | | Worst conditions |
| Availability | 99.671% | 99.749% | 99.982% | 99.991% |
| Annual downtime of load | 28.8 hours | 22 hours | 1.6 hours | 0.8 hours |

After the design of the power demand and structure of the datacentre, **IT IS NECESSARY LOOKING FOR THE TYPE AND NUMBER OF UPS UNITS TO BE INSTALLED.** We give two sample topologies below:

Power demand 100 kVA (in this example, an UPS with a capacity of 100 kVA is used):

- › Tier I: single UPS 100 kVA;
- › Tier II and Tier III: single system consisting of two UPSs 100 kVA each in parallel, providing N + 1 redundancy;
- › Tier IV: Two separate UPSs 100 kVA each, one for each distribution path.

Power demand 1,000 kVA (in this example, UPSs with a capacity of 500 kVA are used):

- › Tier I: Two UPSs 500 kVA each in parallel to supply 1,000 kVA of power;
- › Tier II and Tier III: single system consisting of 3 x 500 kVA UPS units in parallel, configured to deliver 1,000 kVA with an N + 1 redundancy;
- › Tier IV: Two systems, each consisting of two 500 kVA UPS units in parallel to supply 1,000 kVA to each distribution path.

THE TYPE OF UPS CAN BE FURTHER DIFFERENTIATED:

UPS units installed in 19" rack cabinets, typically for medium-low power located close to the critical load and installed in the same room as the datacentre.

UPS units with frame and ventilation systems similar to server racks, that allows UPS to be positioned in line with them.

Modular UPS units, which can be expanded or hot-swapped while the other modules continue to supply the load. This solution makes it possible to increase the power of the UPS to match increases in the critical load power. It may also be used to obtain a N + 1 redundancy, which simplifies the electrical plant. Returning to the previous examples:

- › 100 kVA: UPS with N + 1 internal modules (N depends on the size of the available modules e.g. 6 x 20 kVA modules or 5 x 25 kVA modules).
- › 1,000 kVA: UPS with N + 1 internal modules (N depends on the size of the available modules e.g. 6 x 200 kVA modules or 5 x 300 kVA modules).

In addition it must be also consider the **battery of accumulators** with the needed energy stored for critical load autonomy. These accumulators can be made using various technologies. Below are some examples, listed in ascending order of cost:

Maintenance-free valve-regulated lead-acid (VRLA) accumulators.

These are the most commonly used accumulators thanks to their favourable price-performance ratio. The accumulators are mainly divided by life expectancy: 5, 10/12, over 12, 15 and 20 years (the longer the life, the higher the cost and the greater the area occupied). The VRLA accumulators require some technical attention to do with the ventilation to keep the concentration of hydrogen released during operation below 4% (see Standard EN 50272-2 "Stationary batteries"). These accumulators can be installed in a cabinet or on a rack.

Fig. 1: VRLA

- 1 Ventin strip
- 2 Lid
- 3 Case
- 4 Negative plate
- 5 Absorbed glass mat separator
- 6 Positive plate
- 7 Terminal
- 8 Plates connectors
- 9 Through cells welding points
- 10 Safety valve

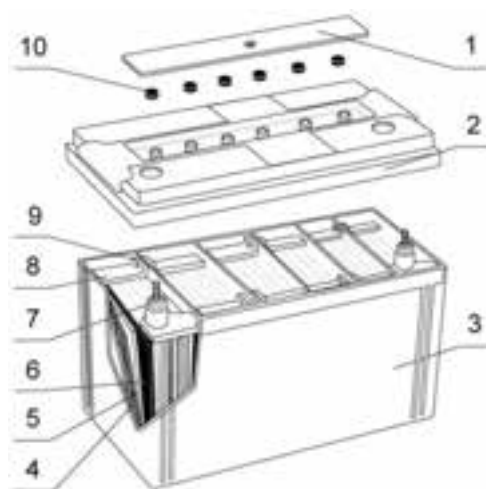

Wet lead-acid accumulators.

These accumulators require maintenance and top-ups of water. Available in various types and with different life expectancies, they must be positioned on racks and must be placed in special rooms with forced ventilation because of hydrogen emissions.

Wet nickel-cadmium accumulators.

These accumulators require maintenance and top-ups of water. They come in several different types and with different life durations, and there are also some very low-maintenance versions. Generally, they require special rooms and forced ventilation for hydrogen emissions. They can be installed on racks and, sometimes, in cabinets.

Lithium-ion accumulators.

Modules with battery monitoring system (BMS), installed in cabinets. These accumulators are known both for high density of energy storage in a smaller size and for their fast charging (approximately 10 times faster than the accumulators described above). BMS is an integral part of the accumulators, which don't require ventilation because they don't emit hydrogen (they don't use water).

Flywheels.

These are accumulators that storage energy with a rotary mass (the flywheel). Sometimes it is used a large mass with a low rotational speed; sometimes it is used a small mass with high rotational speed. Installed in cabinets, they come equipped with electronic control system and power converters for charging, discharging and power interface with the UPS. They don't require ventilation for hydrogen (no water). They provide autonomy for some seconds, to one or two minutes. Generally it is possible to connect more flywheels in parallel to increase autonomy; that anyway it is always very brief.

3 UPS INSTALLATION EVALUATION

To install an UPS system, man have to consider:

- A. Whether the UPS is a single unit or a modular unit (the installation process is similar).
- B. Whether the system is a parallel with some UPS units connected together.
- C. Whether the system is based on two distribution paths, in this case the UPS systems might consist of two identical, independent UPS units, one for each path, and often placed in separate rooms.
 - a. Dual distribution path systems may contain loads that have a single supply input line. If the plant design requires power redundancy also for these loads, by, for example, adding static transfer switches into the server racks, then it will be necessary also to include a system for the synchronization of the UPS units on each path, in order to optimize the power switching.
- D. Whether the UPS could be supplied from a single line, or from two lines in function of UPS type, one line for leading to the rectifier input and the other for bypass input (this is an alternative line that supplies the load when the inverter cannot be used). With two lines, the fault circuits can be separated and availability improved.
 - a. Static switch inside the UPS may be subject to fault with energy backfeed to the supply line, with safety risk for person, the UPS units will include an alarm interface that must be connected to a tripping coil that command the switching off of a circuit breaker or a contactor on upstream bypass line. Considering the backfeed protection it is useful to have two lines to maintain the supply to the critical load.
- E. Whether the system has an external bypass switch, which is useful for some types of maintenance.
 - a. If the UPS is equipped with an internal bypass switch for maintenance purposes, and if the UPS system is single or double in redundant parallel, this switch is a designer's free choice.
 - b. If the system consists of two UPS units power parallel (for example 2 x 100 kVA serving a 150 kVA critical load) or by three or more UPS units, an internal switch cannot be used, and so an external switch is needed. If an external bypass switch is used, it is important:

- i. To use a lock or padlock
 - ii. to prescribe procedures for its proper use
 - iii. to add an output switch for each UPS unit.
- F.** Whether residual current device (RCD) upstream or downstream of the UPS need to be used.
- a. Downstream: the typology depends on the characteristics of the critical load and electrical plant
 - b. Upstream: it must be consider the leakage current of the UPS added to the leakage current of the load. Standard EN 62040-1 “Uninterruptible power systems (UPS) - General requirements and safety” prescribes the use of a type-A RCD for a single-phase UPS and a type-B RCD for three-phase UPS. Only devices for indirect contact, selective or delayed, may be used.
- i. In a TN-S system, the UPS units generally do not need upstream RCD, it is a designer’s choice.
 - ii. The RCD must be positioned upstream of all the supply line if the UPS is single RCD (on the common electrical node then, immediately downstream, two circuit breakers one each input lines) or, in case of a parallel system set-up, RCD must be installed upstream all supply lines for UPS units, as well as upstream of an external maintenance bypass switch, where such exists.

Fig. 2: RCD upstream of all the supply lines of all the UPS units in a parallel system.

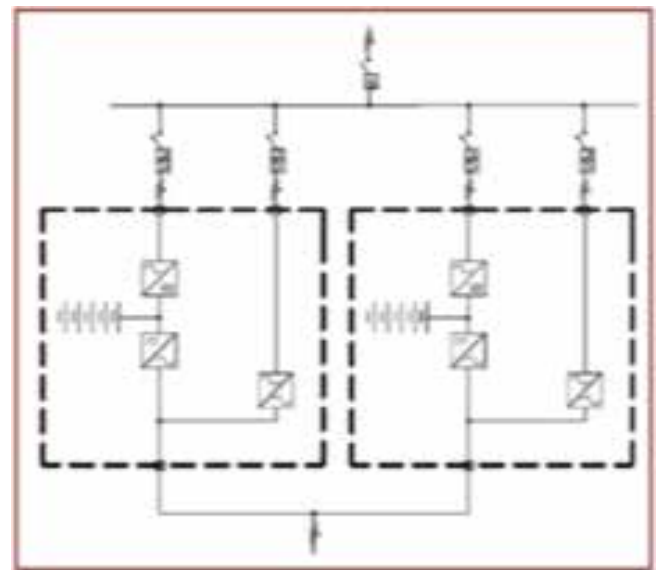

- G.** Whether the UPS is equipped with an additional transformer, installed at the output or input, to recreate for example a TN-S system. It is necessary to be aware that:
- a. It increases the power dissipation.
 - b. It requires an inrush current at power-up (which can be reduced to within certain limits). Accordingly, the circuit breaker upstream of the primary transformer and/or the static bypass switch inside the UPS must be able to withstand the inrush current without failing or switching off.
 - c. It changes the short-circuit and ground fault currents downstream of the secondary circuit, which needs to be taken into account when installing the system or reviewing the electrical plant design.

Fig. 3: UPS with an external transformer connected to the output

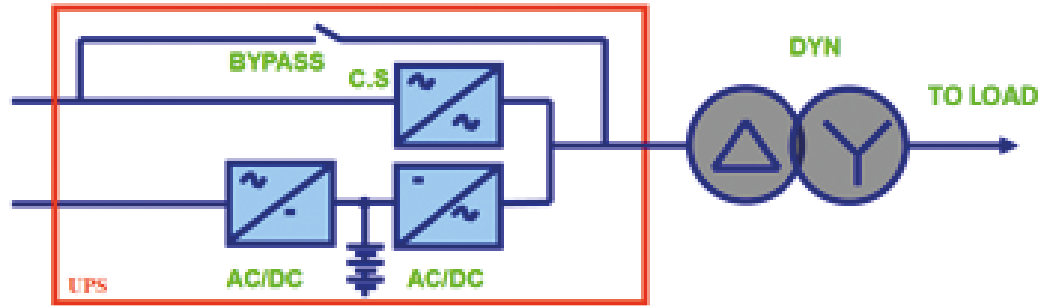

- H. Whether the UPS is installed downstream of the automatic transfer switch (ATS) mains/generator. If this configuration is used, the following factors need to be taken into consideration:
 - a. The maximum input current that the UPS absorbs.
 - b. Whether the UPS has an inrush current at the start-up of the rectifier.
 - c. The values of the harmonic distortion and the power factor of the UPS rectifier.
 - d. The value of the sub-transient reactance of the alternator.
 - e. Whether it is possible to inhibit the recharging of the battery when UPS is supplied by generator, with an alarm contact from ATS.
 - f. Whether the UPS can absorb the input current with a ramp at the start-up of rectifier.
 - g. Whether, in the presence of multiple UPS in parallel or in the presence of several UPS systems, the start-up of each rectifier for each UPS can be delayed.
- I. Whether the UPS is capable of supply loads with a high power factor - from 0.9 up to 1 - for example in dual distribution path systems.
- J. Whether the UPS includes a user alert interface, such as an alarm, SNMP, MIB, Web Browser, Modbus, or BACnet.



Fig. 4: UPS connected over a LAN using the Simple Network Management Protocol (SNMP)

- K. Whether the UPS is equipped with a remote monitoring system linked to the supplier/manufacturer's service centre.



4 UPS MAINTENANCE EVALUATION

When framing a *business continuity* plan, many organizations overlook the [importance of technical support](#). Hardware failures are often viewed as normal, but without a preventive approach to their management, they can quickly turn into irremediable disasters with serious financial consequences for the organization's reputation.

The availability of mission-critical devices such as an UPS depends on various factors, including project design, operational and maintenance procedures.

Even though the infrastructure design may have been appropriate at the time of installation, problems may arise over time as the components age or as external events leading to malfunctions occur.

It is therefore essential to have [maintenance carried out by specialized personnel](#). Equipment servicing can be organized in several ways: in response to a customer reporting a fault, as part of an ongoing maintenance contract providing for one or more annual on-site check-ups, or through the [remote monitoring](#) of the UPS.

Periodic maintenance, for example, provides one or more visits to be made during the year by technicians who will check the equipment operation, carry out cleaning, replace spare parts (e.g. fans), update the software and upgrade the hardware.

Remote diagnostic using one of the various forms of connection available on UPS enables to communicate with the manufacturer's control centre to acquire information about UPS operation (including the signalling of internal and external events).

It is also possible for UPS unit itself to make emergency calls and transmit details of the fault, which often has the advantage of avoiding the need for multiple call-outs since the maintenance personnel can arrive with the necessary spare parts on the first visit.

Fig. 5: Fault will be fixed at the first visit if UPS is connected to the manufacturer's control centre.

ON-SITE DIAGNOSTICS

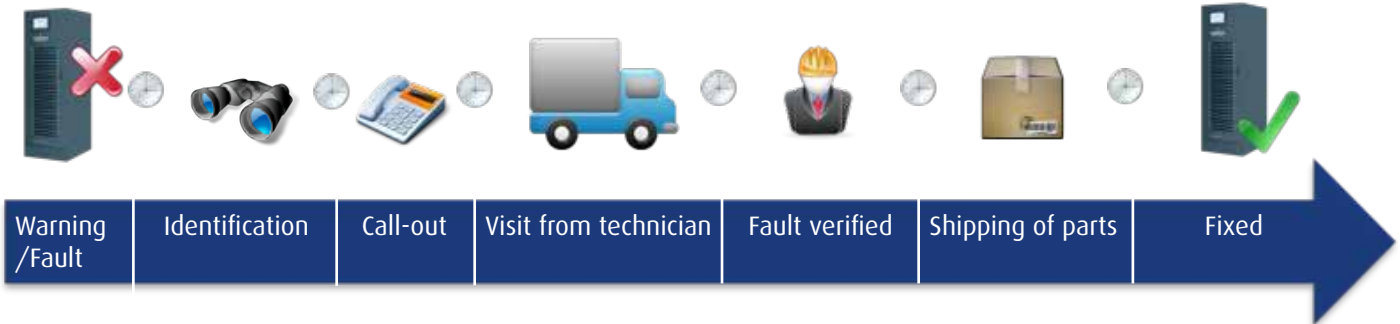

REMOTE DIAGNOSTICS



5 ENERGY SAVING EVALUATION

Minimizing energy consumption and hence the emission of CO₂ is an indispensable aspect of operating a modern system.

As UPS systems achieve ever higher levels of efficiency, they enable significant reductions to be made in energy consumption.

The replacement of old with new and more efficient UPS systems offers the [following advantages](#):

- › Direct energy savings.
- › Indirect energy savings from the reduced use of cooling systems.

The product standard for the UPS, EN 62040-3 “Uninterruptible power systems (UPS) - Methods of specifying the performance and test requirements”, indicates **three types of UPS**:

1. VFD: An offline/standby UPS (greatest energy saving)

- › Standby UPS with VFD (Voltage-Dependent Frequency): the output voltage and frequency depend on the input voltage and frequency.
- › Under normal conditions, the bypass switch is on (closed) and the current flows into the system.
- › Under emergency conditions and within a few milliseconds, the power is switched to the battery and delivered to the system via an inverter.
- › There is no conditioning of the voltage or frequency between UPS input and output to load.
- › About the three configurations, this is the most energy efficient.

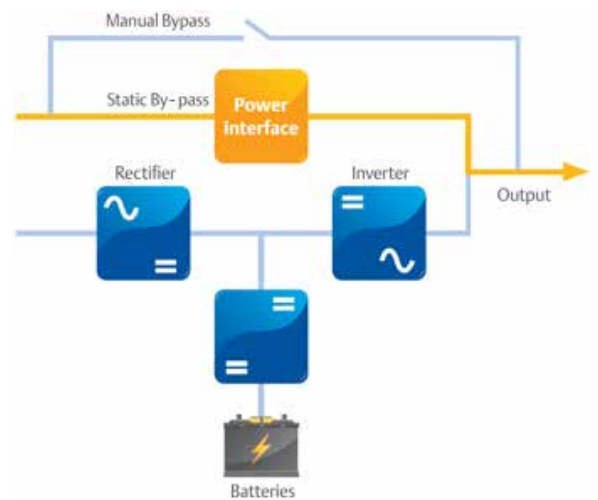

Fig. 6: Offline VFD UPS

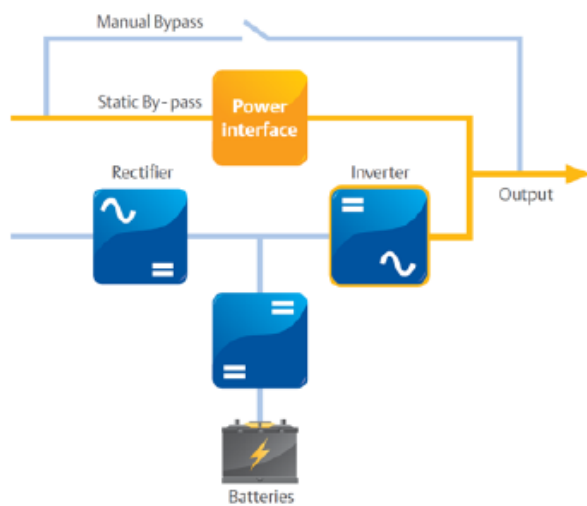

Fig. 7: Interactive VI UPS

2. VI: A line-interactive UPS (lower energy consumption achieved by conditioning the output voltage)

- › Line-interactive VI (Voltage Independent) UPS, the output voltage is independent from the input voltage.
- › Under normal conditions, the mains is filtered so that the UPS output provides a better voltage/ power quality (e.g. the current flows through an internal stabilizer or through an inverter that can operate as an active filter).
- › Under emergency conditions and within a few milliseconds, the power is delivered by the battery via an inverter.
- › There is no conditioning of the frequency between the UPS input and output to load.

3. VFI: An online/double-conversion UPS (maximum protection, lowest energy saving)

- › Double-conversion VFI (Voltage-Frequency Independent) UPS: the output voltage and frequency are independent of the input voltage and frequency.
- › The first conversion is when the alternating current (AC) of the mains is converted into a direct current (DC) by the rectifier. The DC voltage charges or maintains the batteries, and supply the input of the inverter.
- › The second conversion is made by inverter that converts the direct current into an alternating current. Under emergency conditions, the inverter continues to be supplied by internal DC bus.

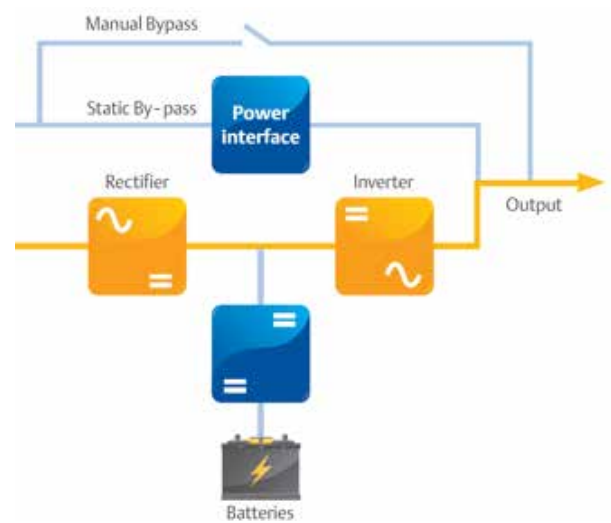

Fig. 8: Double conversion VFI UPS

THE UPS ENERGY SAVING WILL DEPEND ALSO ON WHETHER A HIGH-EFFICIENCY VI OR VFD CONFIGURATION IS USED. THE FOLLOWING FACTORS NEED TO BE TAKEN INTO ACCOUNT:

The quality of the utility supply (mains): if it is not reliable enough, the load is at risk of shutdown or fault.

The quality of the load (which is directly powered from the mains): if the current distortion is high and the power factor is low, the savings on electricity are cancelled out by the fines imposed by the electricity supplier.

It is important to ensure that the UPS retains its high level of efficiency even at low load levels, because an UPS almost never works at a 100% load.

For this reason, manufacturers have considerably [improved the efficiency](#) of the latest UPS units by incorporating the most modern technologies, which include:

The latest generation of Insulated Gate Bipolar Transistors (IGBTs).

IGBT connection types that minimize losses when converters used.

Systems that monitor and reduce fixed losses (e.g. through the control of fan speeds) to increase efficiency even at low loads.

Systems to optimize performance for loads between 50% and 75% of the nominal power, which is the most typical range in which an UPS operates.

Systems that enable the upstream mains to supply the load using standby VFD and line-interactive VI modes, with continuous network quality control and fast transfer switching, which also increases the efficiency by three percentage points compared to the VFI (double-conversion) mode.

UPS parallel systems that allow to inhibit the surplus UPS units when the load is light, and allow fast restarting when the power demand of the load increases.

Additional energy savings can be made by using a modular UPS system, because:

The initial cost can be minimized by deploying only as many modules as the load demands.

The deployment of the minimum number of modules as possible enables the converters to be run at maximum efficiency.

Other modules can be added as necessary to follow the progressive increase in the load.

It permits the inhibition of the extra modules in case of low loads.

It enables the completely safe hot-swapping of faulty modules without interrupting the power supply to the load.

It simplifies maintenance and reducing service times.

It can be equipped with one or more redundant modules, e.g. $N + 1$, where N is the total power of the minimum number of modules needed to supply the effective load.

Used by a broad variety of different applications, [datacentres are vital to the functioning of a today's systems of production](#) and the modern economy. When opting for an UPS, it is therefore vital to choose a type suited to its task, and ensure that the installation and servicing are done properly. Getting the choices right will not only guarantee the adequate supply of power to the load, high availability and operational safety, but will also make it possible to take a global approach to the datacentre, to control the system remotely or locally as needed, and to achieve considerable energy savings.





 **ANIE**
AUTOMAZIONE



Federazione ANIE

ANIE Automazione

Viale Lancetti 43 - 20158 Milan - Italy

Ph. 02 3264.252 - Fax 02 3264.327

anieautomazione@anie.it

www.anieautomazione.it

www.anie.it